



50mm Wire Wound Potentiometer

PW50



Part Number

PW50- 10Ω, L - 25 KC

Resistance Value

Shaft Type

Shaft Length

Dimensions

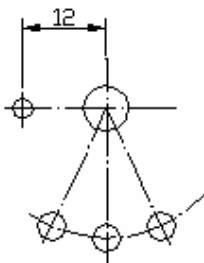
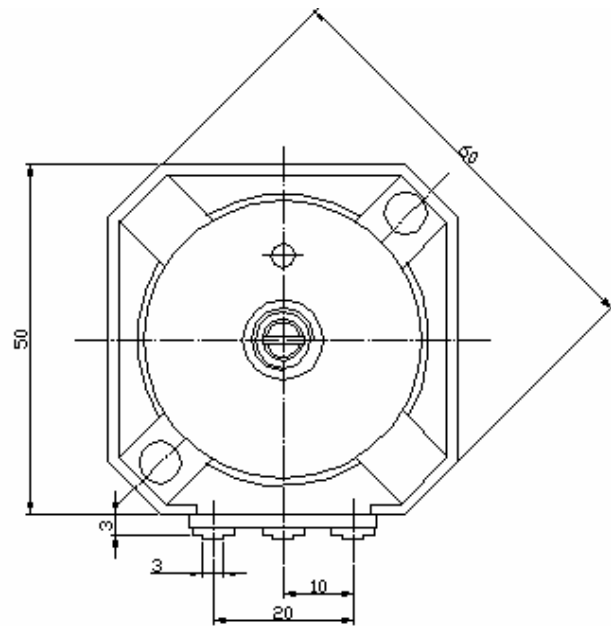
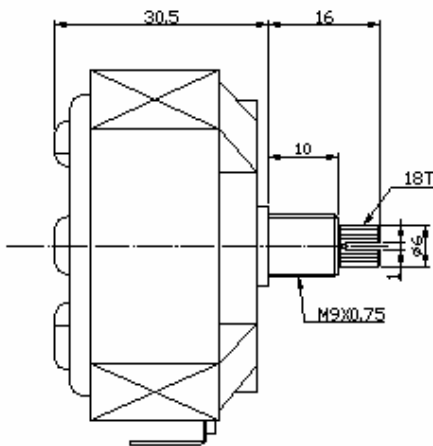



50mm Wire Wound Potentiometer

MECHANICAL SPECIFICATION :

1. ANGLE : 300°+/-5°
2. ROTATIONAL TORQUE : 50~300g/cm
3. NUT FASTENING STRENGTH : 10~12 kgf.com
4. SHAFT ANTI ROTATION STRENGTH : 1 kgf over
5. ROTATIONAL LIFE : 15,000 cycles min

ELECTRICAL SPECIFICATION :

1. RATED POWER : DC- 30 W
2. RESISTANCE TAPER : B TAPER
3. RESISTANCE TOLERANCE : +/-20%
4. INSULATION RESISTANCE : over 100M ohm with DC500V put
between the terminal and the shaft.
5. WITHSTANDING VOLTAGE : one minute against 50HZ 500V put
between the terminal and the shaft.
6. TEMPERATURE RANGE : -10°~70°C degree
7. RESISTANCE RANGE : 5 ohm ~ 50 ohm