



Standard Type Metal and Plastic Shaft Slide Potentiometers

SL-2015G



Part Number

SL2015G- **B** **50K** ,L - **20** **C** / **M**

Taper Resistance Value Shaft Type Lever Material
Shaft Length

Dimensions

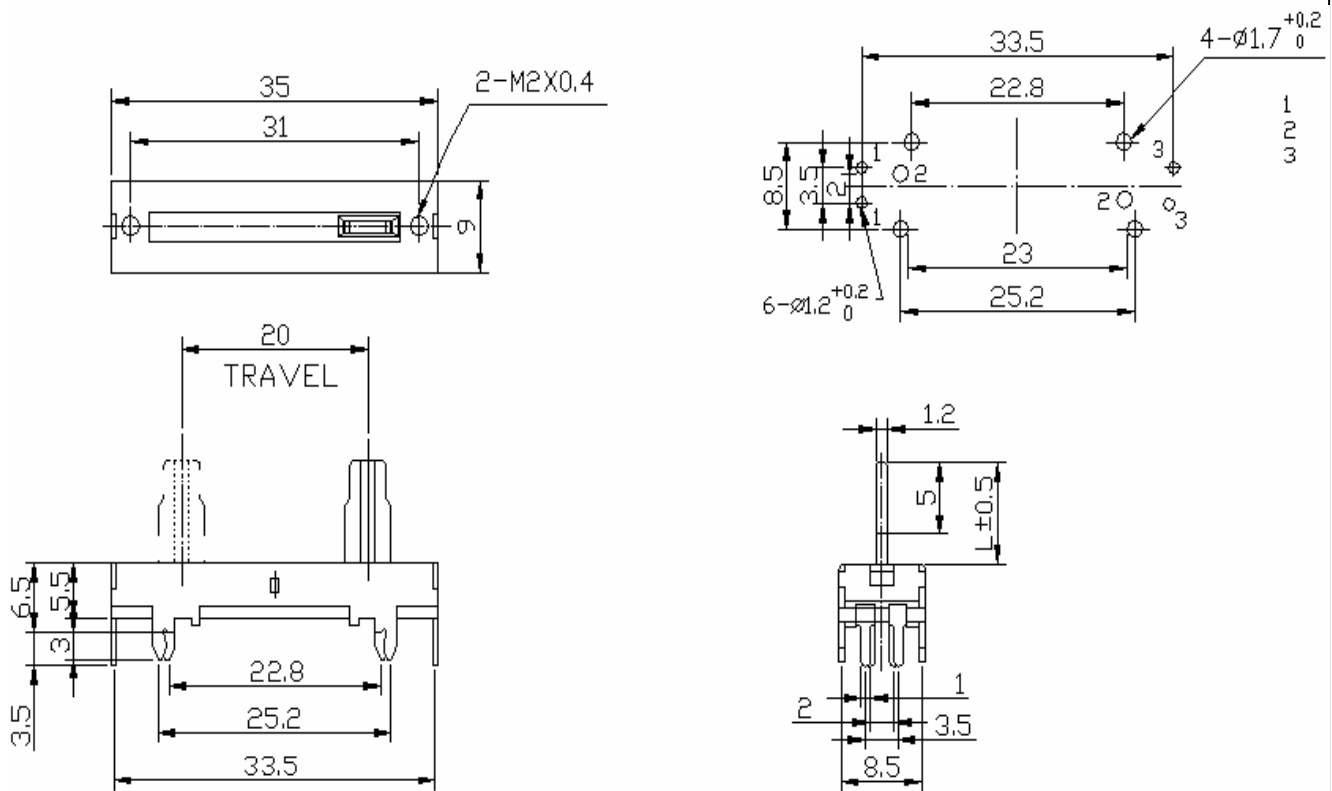



Standard Type Metal and Plastic Shaft Slide Potentiometers

Shaft Type

Insulated Lever

MATERIAL	INSULATED LEVER																					
LEVER TYPE	C-TYPE				CA-TYPE				B-TYPE													
DIMENSIONS																						
LENGTH(L)	L	5	10	12.5	15	18	20	L	5	10					L	10						
	F	5	5	5	5	5	5															

Metal Lever

MATERIAL	METAL LEVER																				
LEVER TYPE	A-TYPE			D-TYPE			C-TYPE			B-TYPE											
DIMENSIONS																					
LENGTH(L)	L	10.4		L	10	15	20	25	L	10	15	20	25	17.3	L	10	15				
	F	7		F	7	10	10	10	F	7	10	10	10	10							



Standard Type Metal and Plastic Shaft Slide Potentiometers

Electrical Characteristics

Total Resistance	5K Ω ~1M Ω				
Total Resistance Tolerance	$\pm 20\%$ (more than 1M Ω $\pm 30\%$)				
Resistance Taper	A. B. C. D. W. Taper				
Resistance Taper Characteristics	A50%	B50%	C50%	D50%	W50%
	15-25%	40-60%	75-85%	2-15%	45-55%
Rated Power	B Taper: AC200V 0.2 W; Other Tapers AC150V 0.1 W				
Residual Resistance	$R \geq 250K\Omega$ 0.1% $250K\Omega > R > 10K\Omega$ 20 Ω Max. (between Term. 1, 2) $10K\Omega \geq R$ 20 Ω Max. (between Term. 2, 3)				
Gang Error	-40 ~ 0db \leq 3 db				
Noise	100mV Max.				
Insulation Resistance	DC 250V 10M Ω				
Withstand Voltage	1 minute at AC 300V				
Sliding Life	15,000 Cycles				

Mechanical Characteristics

Overall Travel	20 mm \pm 0.5 mm
Stopper Strength	5 kgf.cm max. / 3 sec. (From the base level to a point of 2mm).
Operating Force	30~200gf.cm
Click slip-out force	50gf.cm ~ 350 gf.cm
Lever Push-Pull Strength	3 kgf.cm max. at 10 sec.
Lever Wobble	2(2*L)/20 mm max. (L:lever length both side)
Bending Moment	25mN.m (250gf.cm)
Soldering Heat	300 $^{\circ}$ C, 3s. (Only for Hand-Soldering)
Lever Deviation	0.5 max. (one side)